



HANGCHA GROUP CO., LTD.

Factory site: 666 Xiangfu Road,
Hangzhou, Zhejiang, China (311305)

Tel: +86-571-88926735 88926755
Fax: +86-571-88926789 88132890

sales@hcforklift.com
www.hcforklift.com



Follow us on
Facebook



Follow us on
YouTube



Follow us on
WeChat



Download "Hangcha
Forklift" App



ISO45001
ISO45001:2018



ISO14001
ISO14001:2015



ISO9001
ISO9001:2015



HANGCHA trucks conform
to the European Safety
Requirements.

2025 VERSION 1, COPYRIGHT 2025/03

HANGCHA GROUP CO., LTD. reserves the right to make any changes without notice concerning colors, equipment, or specifications detailed in this brochure, or to discontinue individual models. The colors of trucks, delivered may differ slightly from those in brochures.



X Series Diesel / Gasoline / LPG Counterbalanced Forklift Trucks

with capacities of 1,500 to 3,800kg

The World of Hangcha



X Series

Diesel / Gasoline / LPG
Counterbalanced
Forklift Trucks



Innovation design

The X series is the new series of internal combustion counterbalance forklift truck developed by Hangcha independently, adopting the world advanced technologies based on the original products. Through the comprehensive upgrading of appearance molding, energy conservation, environmental friendly, comfort, security and reliability, it will become the world-class forklift truck which can meet your overall demands.

Strong appearance and visual impact

The appearance of full truck is developed under the cooperation with professional industrial design company by adopting the appearance design methods of brand-new concept. The streamlined surface modeling design brings smooth lines, elegant appearance, vigorous and steady surface as well as the outstanding inherence, possessing the powerful visual impact.

The truck is small, exquisite and concise. which adopting the newly designed parts with opening mould at large area, the appearance of full vehicle will be more humanized.



The new designed mast increase forward visibility 15%



Noise ↓ 3dB



Legroom ↑ 30%



High pressure common rail electronic-controlled engine provide lower failure rate (Common rail engine)



Floating structure decrease the vibration by 10%



Exhaust emission ↓ 35% (Common rail engine)



Grade-speed ability ↑ 10% (Common rail engine)



Aluminous plate-fin radiator provides stronger structure



Prolong the service life of steering axle 20%



Fuel consumption ↓ 10% (Common rail engine)



Better cold starting performance (Common rail engine)



Water temp ↓ 10 C, oil temp ↓ 10%

Energy conservation and Environmental friendly



The high pressure common rail electronic-controlled engine which adopts high pressure multiple injections technology to ensure the strong power take-off, lower emission and better cold starting performance; saving the 10% of energy consumption.



The whole truck adopts LED lights as shiner and new-type panoramic retroreflector to ensure energy conservation and power saving as well as greatly improve the performance and service life of luminaires at the same time.

The truck all adopt the environmental friendly material to reduce environmental hazards.

Maintenance

Integral locking pin structure on the hood can be opened without tool, which is convenient for daily repair and maintenance.



Adoption of new generation integrated electric box makes maintenance and repair convenient, layout becomes more reasonable and with better water-proof performance.

The enlarged opening angle of hood and increase of left and right hood side plates can provide you with convenient and rapid maintenance mode.



Newly-developed LCD instrument has more comprehensive functions and more stable performance and entirely displays the full truck state, fault code and other important information, which can make the operator more intuitively and conveniently have a better knowledge of truck state and make the maintenance conveniently.

Fully improved reliability And security



1. The radiator adopts aluminous plate-fin radiator with better performance and higher structural strength independent oil radiator, optimized oil and water heat dissipation channel and double ventilation holes on counterweight can greatly improve cooling efficiency and reliability of overloaded operation and ensure reliable operation of the engine.

2. 2.0~3.8t roller bearing on the steering axle king pin adopts large size tapered roller bearing (TRB), larger steering cylinder and bumper block assemblies on the top, which can prolong the service life of bearing and highly improve the reliability of steering axle.

3. Overhead guard adopts special-shaped steel tube, which can reinforce the strength and improve sealing of the cab.

4. Optimized hydraulic breather structure and integrated with return oil filter can prolong the service life of hydraulic pressure system.



Comfort

Option of the most advanced full floating structure in the world can minimize the vibration of full truck and support more superior buffer, micro-motion and starting functions at the same time. With several imported engines, they can constitute more perfect engine-transmission system.

Reduce the caster angle of instrument stand and adopt the integral hood to greatly increase the space underfoot; The orthodrome of overhead guard fore leg will expand the driving space;



Adopt the new-type of box iron. Increase the inside width of inner mast and the spacing between lifting cylinders. The lowering of instruments in the cabin will greatly increase the forward visibility; The rear visibility will also be greatly improved through the optimization design of counterweight.



The design of steering wheel of small diameter and electro-hydraulic reversing as well as the car-type double-handle combination switch will greatly improve the driving comfort.

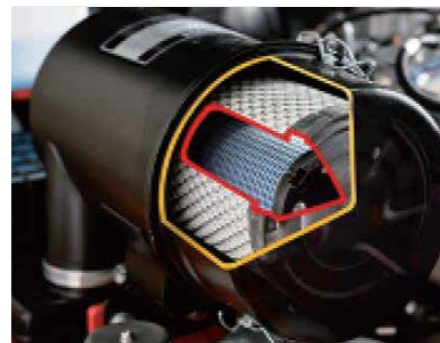

Optimized air intake and exhaust system, high-capacity exhaust silencer and high-effect intake muffler will reduce the noise of full truck by 3dB and reduce the vibration by 20%.

Intelligentized management system (option)

Reserved plug of extending function of Intelligent module is on the wire bundles that makes truck management more convenient and rapid.



Standard Specification

- / Cover of tilt cylinder
- / Traction device
- / LED working light
- / Hydraulic oil filter
- / Electric Flameout
- / Seat with belt
- / Skidproof pedal
- / Air filter
- / Hydraulic oil dipstick
- / Mast speed limiting valve
- / Full hydraulic power steering
- / Wide view duplex mast
- / Standard forks
- / Standard overhead guard
- / Rear combination LED light
- / Panoramic rearview mirror
- / Filf folder
- / Adjustable steering column
- / Pre-heating indicator
- / Engine fuel pressure warning
- / Neutral switch
- / Engine hood spring
- / Dipstick
- / Pneumatic tyres
- / Standard load backrest
- / Horn
- / Fuel gauge
- / LCD display
- / Cable parking brake
- / Tilt cylinder self-locking valve
- / Fork carriage mounting class II(III)
- / Timer
- / Load safety valve
- / Charging indicator
- / Water temperature gauge
- / Reversing buzzer
- / Return oil filter
- / Hand grip
- / Integrated controller
- / Oil-water separator
- / Engine fault warning
- / Rubber pedal
- / 2nd hydraulic function
- / Transmission oil temperature warning
- / Dynamic load sensing system (for desel engine)

Optional Mast

- / Duplex wide view full free mast
- / Trilex wide view full free mast
- / Special duplex wide view mast
- / Wider fork carriage
- / Special forks

Options

- / Dual front wheel
- / Cabin
- / High-positioned exhaust system
- / Customer painting
- / Cabin heater
- / LED rear working light
- / Hood lock
- / Double heat insulating pad and leather cover
- / Net cover of radiator
- / Solid tyre
- / Middle-positioned exhaust system
- / Sparkle arrester
- / Suspension seat
- / Purified exhaust system
- / Fuel tank lock
- / Speed meter
- / Extinguisher
- / Right rear armrest with horn button
- / Counter weight net
- / Height of overhead guard
- / Dual air filter
- / Milometer
- / Speed limiter (Electronic-Controlled engine)
- / Emergency switch
- / Fan protector
- / Over-speed alarm
- / Warning light
- / OPS system
- / Waterproof cover on the guard
- / Toolbox

Optional Attachments

- / Paper roll clamp
- / Rotating bale clamp
- / Load stabilizer
- / Multi-drum clamp
- / Bale clamp
- / Drum clamp
- / Dumping clamp
- / Crane arm
- / String pole
- / Weigher system
- / Sideshifter
- / Rotating forks
- / Fork extensioner
- / Load release device
- / Carton clamp
- / Push-pull device
- / Bucket
- / Hook
- / Lengthened fork

X Series Diesel / Gasoline / LPG Counterbalanced Forklift Trucks

Distinguishing mark	HANGCHA GROUP CO.,LTD.											
	CPCD15-XRW10	CPCD18-XRW10	CPCD20-XRW10	CPCD25-XRW10	CPCD30-XRW10	CPYD20-XRW52F	CPYD25-XRW52F	CPYD30-XRW52F	CPYD35-XRW52F	CPYD38-XRW52F		
1.1	Manufacturer											
1.2	Manufacturer's type designation											
1.3	Drive: electric (battery or mains), diesel, petrol, fuel gas											
1.4	Operator type: hand, pedestrian, standing, seated, order-picker											
1.5	Rated capacity/rated load	Q (kg)	1500	1750	2000	2500	3000	2000	2500	3000	3500	3800
1.6	Load centre distance	c (mm)	500	500	500	500	500	500	500	500	500	500
1.8	Load distance, centre of drive axle to fork	x (mm)	405	410	460	460	475	460	460	475	480	480
1.9	Wheelbase	y (mm)	1475	1475	1650	1650	1700	1650	1650	1700	1700	1700
2.1	Service Weight	kg	2720	2880	3450	3850	4380	3450	3850	4380	4750	4950
2.2	Axle loading, laden front/rear	kg	3720/500	4110/520	4750/700	5540/810	6450/930	4750/700	5540/810	6450/930	7200/1050	7650/1100
2.3	Axle loading, unladen front/rear	kg	1300/1420	1290/1590	1600/1850	1560/2290	1700/2680	1600/1850	1560/2290	1700/2680	1700/3050	1650/3300
3.1	Tyres: solid rubber, superelastic, pneumatic, polyurethane		Pneumatic	Pneumatic	Pneumatic	Pneumatic	Pneumatic	Pneumatic	Pneumatic	Pneumatic	Pneumatic	Pneumatic
3.2	Tyre size, front		6.5-10-10PR	6.5-10-10PR	7.00-12-12PR	7.00-12-12PR	28*9-15-14PR	7.00-12-12PR	7.00-12-12PR	28*9-15-14PR	28*9-15-14PR	28*9-15-14PR
3.3	Tyre size, rear		5.00-8-10PR	5.00-8-10PR	6.00-9-10PR	6.00-9-10PR	6.50-10-10PR	6.00-9-10PR	6.00-9-10PR	6.50-10-10PR	6.50-10-10PR	6.50-10-10PR
3.5	Wheels, number front / rear (x = driven wheels)		2*/2	2*/2	2*/2	2*/2	2*/2	2*/2	2*/2	2*/2	2*/2	2*/2
3.6	Tread, front	b10 (mm)	900	965	965	965	1005	965	965	1005	1005	1005
3.7	Tread, rear	b11 (mm)	920	920	973	973	975	973	973	975	975	975
4.1	Tilt of mast/fork carriage forward/backward	α/β(°)	6/12	6/12	6/12	6/12	6/12	6/12	6/12	6/12	6/12	6/12
4.2	Height, mast lowered	h1 (mm)	1995	1995	1999	1999	2054	1999	1999	2054	2169	2169
4.3	Free lift	h2 (mm)	155	155	160	160	165	160	160	165	170	170
4.4	Lift	h3 (mm)	3000	3000	3000	3000	3000	3000	3000	3000	3000	3000
4.5	Height, mast extended	h4 (mm)	3955	3955	4045	4045	4140	4045	4045	4140	4140	4140
4.7	Height of overhead guard (cabin)	h6 (mm)	2120(2200)	2120(2200)	2120(2200)	2120(2200)	2150(2230)	2120(2200)	2120(2200)	2150(2230)	2150(2230)	2150(2230)
4.8	Seat height relating to SIP	h7 (mm)	1145	1145	1145	1145	1175	1145	1145	1175	1175	1175
4.1.2	Coupling height	h10 (mm)	310	310	320	320	350	320	320	350	350	350
4.1.9	Overall length	l1 (mm)	3205	3240	3615	3680	3770	3615	3680	3770	3850	3880
4.2.0	Length to face of forks	l2 (mm)	2285	2320	2545	2610	2700	2545	2610	2700	2780	2810
4.2.1	Overall width	b1/b2 (mm)	1090/1485	1090/1485	1155/1595	1155/1595	1225/1725	1155/1595	1155/1595	1225/1725	1225/1725	1225/1725
4.2.2	Fork dimensions	s/e/l (mm)	35*100*920	35*100*920	40*122*1070	40*122*1070	45*122*1070	40*122*1070	40*122*1070	45*122*1070	50*122*1070	50*122*1070
4.2.3	Fork carriage DIN 15 173 --- ISO 2328, class/type A,B		Class A	Class A	Class A	Class A	Class A	Class A	Class A	Class A	Class A	Class A
4.2.4	Fork-carriage width	b3 (mm)	1000	1000	1038	1038	1100	1038	1038	1100	1100	1100
4.2.5	Distance between fork-arms	b5 (mm)	200-1000	200-1000	244-1038	244-1038	244-1100	244-1038	244-1038	244-1100	244-1100	244-1100
4.3.1	Ground clearance, laden, below mast	m1 (mm)	115	115	105	105	130	105	105	130	130	130
4.3.2	Ground clearance, centre of wheelbase	m2 (mm)	145	145	150	150	170	150	150	170	170	170
4.3.4.1	Aisle width for pallets 1000 x 1200 crossways	Ast (mm)	3640	3670	3930	3990	4075	3930	3990	4075	4120	4160
4.3.4.2	Aisle width for pallets 800 x 1200 lengthways	Ast (mm)	3840	3870	4130	4190	4275	4130	4190	4275	4320	4360
4.3.5	Turning radius	Wa (mm)	2035	2060	2270	2330	2400	2270	2330	2400	2440	2480
4.3.6	Minimum pivoting point distance	b13 (mm)	600	600	780	780	810	780	780	810	810	810
5.1	Travel speed, laden/unladen	km/h	16.5/17.5	16.5/17.5	20/21	20/21	18/19	20/21	20/21	18/19	18/19	18/19
5.2	Lift speed, laden/unladen	m/s	0.5/0.55	0.5/0.55	0.55/0.60	0.55/0.60	0.46/0.50	0.55/0.60	0.55/0.60	0.46/0.50	0.38/0.45	0.38/0.45
5.3	Lowering speed, laden/unladen	m/s	0.45/0.50	0.45/0.50	0.45/0.50	0.45/0.50	0.45/0.50	0.45/0.50	0.45/0.50	0.45/0.50	0.35/0.40	0.35/0.40
5.5	Drawbar pull, laden/unladen	N	17000/10500	17000/10500	19800/12500	19800/12500	20800/14500	19800/12500	19800/12500	20800/14500	20800/14500	20800/14000
5.7	Gradeability, laden/unladen	%	25/25	25/25	25/25	25/25	25/25	25/25	25/25	25/25	20/20	20/20
5.1.0	Service brake		Hydraulic	Hydraulic	Hydraulic	Hydraulic	Hydraulic	Hydraulic	Hydraulic	Hydraulic	Hydraulic	Hydraulic
	Parking brake		Mechanical	Mechanical	Mechanical	Mechanical	Mechanical	Mechanical	Mechanical	Mechanical	Mechanical	Mechanical
7.1	Engine manufacturer/type		ISUZU/GK-C240NKFC-01	ISUZU/GK-C240NKFC-01	ISUZU/GK-C240NKFC-01	ISUZU/GK-C240NKFC-01	ISUZU/GK-C240NKFC-01	GCT/GK25 LPG	GCT/GK25 LPG	GCT/GK25 LPG	GCT/GK25 LPG	GCT/GK25 LPG
7.2	Engine power	kw	35.4	35.4	35.4	35.4	35	35	35	35	35	35
7.3	Rated speed	r/min	2500	2500	2500	2500	2400	2400	2400	2400	2400	2400
7.4	Number of cylinders/displacement	(-) / (cm ³)	4/2369	4/2369	4/2369	4/2369	4/2488	4/2488	4/2488	4/2488	4/2488	4/2488
7.9	Vehicle electrical system voltage	V	12	12	12	12	12	12	12	12	12	12
7.1.0	Battery voltage/nominal capacity	V/Ah	12/90	12/90	12/90	12/90	12/90	12/90	12/90	12/90	12/90	12/90
	Rated torque	N·m/r/min	139.9/1800	139.9/1800	139.9/1800	139.9/1800	170/1600	170/1600	170/1600	170/1600	170/1600	170/1600
	Transmissions Manufacturer		China(F)	China(F)	China(F)	China(F)	China(F)	China(F)	China(F)	China(F)	China(F)	China(F)
	Transmissions Type		Powershift	Powershift	Powershift	Powershift	Powershift	Powershift	Powershift	Powershift	Powershift	Powershift
	Stage FWD/RVS		1/1	1/1	1/1	1/1	1/1	1/1	1/1	1/1	1/1	1/1
10.1	Operating pressure for attachments	bar	145	145	175	175	175	175	175	175	175	175
10.2	Oil volume for attachments	l/min	40	40	60	60	60	60	60	60	60	60
10.3	Hydraulic Tank - capacity (drain & refill)	liter	50	50	65	65	65	65	65	65	65	65
10.4	Fuel tank capacity	liter	50	50	65	65	65	65	65	65	65	65
10.7	Sound pressure level at the driver's seat	dB (A)	85	85	85	85	85	85	85	85	85	85

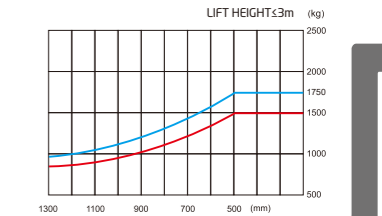
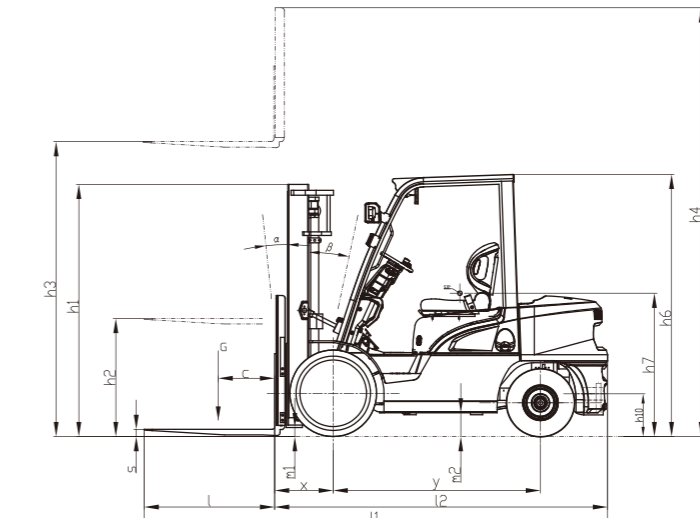

1.5/1.75t

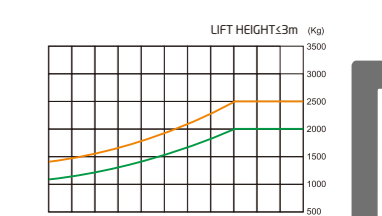

2.0/2.5t

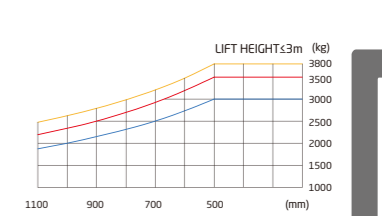

3.0~3.8t

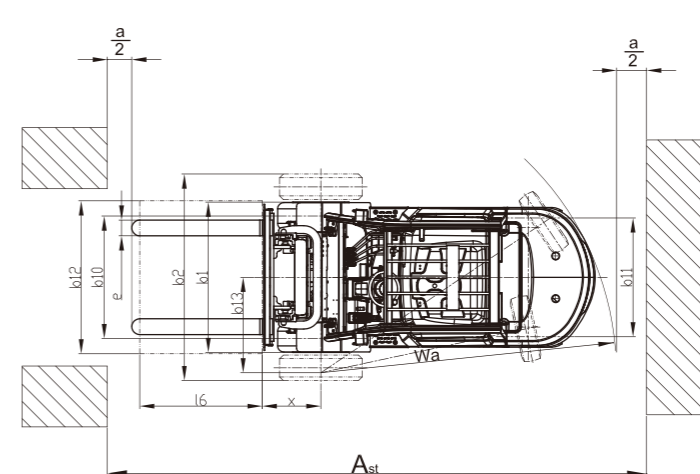

$A_{st} = L_6 + x + W_a + a$ $a = 200\text{mm}$

Optional Engine / Transmission

Engine	Engine manufacturer/type		YANMAR/4TNE92	ISUZU/GK-C240NKFC-01	XINCHAI/4D27XG40	XINCHAI/4D32XG30	XINCHAI/C490BPG	CUMMINS/QSF2.8T3NA49	YANMAR/4TNE98	MITSUBISHI/S4S-DPEU2	GCT/GK21	GCT/GK25	GCT/GK21 LPG	GCT/GK25 LPG
	Manufacturer's type designation		W32	W10	G71J	G72	G2	W43	W33	W55	W21	W22	W51	W52
	Drive		Diesel	Diesel	Diesel	Diesel	Diesel	Diesel	Diesel	Diesel	Gasoline/Gasoline/LPG	Gasoline/Gasoline/LPG	LPG	LPG
	Emission STD		StageIIIA	StageIIIA	/	/	/	StageIIIA	StageIIIA	StageIIIA				
	Engine power	kw/r/min	32.8/2450	35.4/2500	34/2500	45/2500	40/2650	36/2500	42.1/2300	35.3/2250	31.2/2250	37.4/2300	29/2250	35/2400
	Rated torque	N·m/r/min	149/1600	139.9/1800	140/1600-1800	200/1500-1800	160/1800-2000	186/1100-1500	206/1700	177/1700	143.7/1600	176.5/1600	140/1600	170/1600
	Number of cylinders/displacement	ml	4/2659	4/2369	4/2670	4/3168	4/2670	4/2800	4/3319	4/3331	4/2065	4/2488	4/2065	4/2488
Transmission	Powershift	CHINA	x	✓	✓	✓	✓	x	x	✓	✓	✓	x	x
		F(CHINA)	F	✓	✓	✓	✓	✓	✓	✓	✓	✓	✓	✓
		OKAMURA(JAPAN)	B	✓	✓	x	x	x	✓	✓	✓	✓	✓	✓
Rated capacity/rated load		Q (kg)	1500-1750	1500-3000	1500-1750	2000-3800	2000-3800	2000-3800	2000-3800	2000-3500	1500-2500	2000-3800	1500-1750	2000-3800

1.5-1.75t X series mast:(Pneumatic)

Type	Model	Max. fork height	Overall height						Free lift				Tilt range		Capacity			
			Lowered	Extended			Without backrest		With backrest		Front Overhang		F/R	Load capacity at 500mm				
				Without backrest		With backrest	Without backrest		With backrest		Single tire			Dual tire				
				1.5t	1.75t	mm	mm	mm	mm	mm	mm	1.5t		1.75t	1.5t	1.75t		
mm	mm	mm	mm	mm	mm	mm	mm	mm	mm	mm	mm	mm	kg	kg	kg	kg		
Wide view mast	XR15/18M200	2000	1495	2548	2658	2955	155	155	155	405	410	6/6	1500	1750	1500	1750		
	XR15/18M250	2500	1745	3048	3158	3455	155	155	155	405	410	6/12	1500	1750	1500	1750		
	XR15/18M270	2700	1845	3248	3358	3655	155	155	155	405	410	6/12	1500	1750	1500	1750		
	XR15/18M300	3000	1995	3548	3658	3955	155	155	155	405	410	6/12	1500	1750	1500	1750		
	XR15/18M330	3300	2145	3848	3958	4255	155	155	155	405	410	6/12	1500	1750	1500	1750		
	XR15/18M360	3600	2345	4148	4258	4555	155	155	155	405	410	6/12	1500	1750	1500	1750		
	XR15/18M400	4000	2595	4548	4658	4955	155	155	155	405	410	6/12	1500	1650	1500	1700		
	XR15/18M430	4300	2745	4848	4958	5255	155	155	155	405	410	6/6	1450	1600	1450	1650		
	XR15/18M450	4500	2845	5048	5158	5455	155	155	155	405	410	6/6	1400	1550	1400	1600		
	XR15/18M480	4800	2995	5348	5458	5755	155	155	155	405	410	6/6	1350	1500	1350	1550		
Wide view full free duplex mast	XR15/18U250	2500	1760	3074	3184	3445	1186	1076	815	417	422	6/12	1500	1750	1500	1750		
	XR15/18U270	2700	1860	3274	3384	3645	1286	1176	915	417	422	6/12	1500	1750	1500	1750		
	XR15/18U300	3000	2010	3574	3684	3945	1436	1326	1065	417	422	6/12	1500	1750	1500	1750		
	XR15/18U330	3300	2160	3874	3984	4245	1586	1476	1215	417	422	6/12	1500	1750	1500	1750		
	XR15/18U360	3600	2310	4174	4284	4545	1736	1626	1365	417	422	6/12	1500	1750	1500	1750		
	XR15/18U400	4000	2560	4574	4684	4945	1986	1876	1615	417	422	6/12	1500	1650	1500	1700		
	XR15/18N400	4000	1960	4584	4694	4955	1386	1276	1015	425	430	6/6	1400	1550	1400	1600		
	XR15/18N430	4300	2060	4884	4994	5255	1486	1376	1115	425	430	6/6	1350	1500	1350	1550		
	XR15/18N450	4500	2110	5084	5194	5455	1536	1426	1165	425	430	6/6	1300	1450	1300	1500		
	XR15/18N470	4700	2210	5284	5394	5655	1636	1526	1265	425	430	6/6	1250	1400	1250	1450		
Wide view full free triplex mast	XR15/18N480	4800	2260	5384	5494	5755	1686	1576	1315	425	430	6/6	1200	1400	1250	1450		
	XR15/18N500	5000	2360	5584	5694	5955	1786	1676	1415	425	430	6/6	1250	1350	1250	1450		
	XR15/18N550	5500	2560	6084	6194	6455	1986	1876	1615	425	430	3/6	950	1050	1150	1300		
	XR15/18N600	6000	2810	6620	6694	6955	2200	2126	1865	425	430	3/6	700	750	1050	1150		

With sideshifter minus 150Kg,with integral sideshifter minus 100kg.

2.0-2.5t X series mast:(Pneumatic)

Type	Model	Max. fork height	Overall height						Free lift				Tilt range		Capacity			
			Lowered	Extended			Without backrest		With backrest		Front Overhang		F/R	Load capacity at 500mm				
				Without backrest		With backrest	Without backrest		With backrest		Single tire			Dual tire				
				2.0t	2.5t	mm	mm	mm	mm	mm	mm	kg		kg	kg	kg		
mm	mm	mm	mm	mm	mm	mm	mm	mm	mm	mm	mm	mm	kg	kg	kg	kg		
Wide view mast	XR25M250	2500	1749	3207	3546	160	160	460	460	6/12	2000	2500	2000	2500				
	XR25M270	2700	1849	3407	3746	160	160	460	460	6/12	2000	2500	2000	2500				
	XR25M300	3000	1999	3707	4046	160	160	460	460	6/12	2000	2500	2000	2500				
	XR25M330	3300	2149	4007	4346	160	160	460	460	6/12	2000	2500	2000	2500				
	XR25M360	3600	2349	4307	4646	160	160	460	460	6/12	2000	2500	2000	2500				
	XR25M400	4000	2599	4707	5046	160	160	460	460	6/12	2000	2500	2000	2500				
	XR25M430	4300	2749	5007	5346	160	160	460	460	6/6	1950	2400	2000	2500				
	XR25M450	4500	2849	5207	5546	160	160	460	460	6/6	1900	2300	1950	2400				
	XR25M480	4800	2999	5507	5846	160	160	460	460	6/6	1850	2250	1900	2300				
	XR25M500	5000	3099	5707	6046	160	160	460	460	6/6	1800	1900	1850	2250				
Wide view full free duplex mast	XR25M550	5500	3349	6207	6546	160	160	460	460	3/6	1450	1600	1700	1900				
	XR25M600	6000	3599	6707	7046	160	160	460	460	3/6	1000	1050	1500	1750				
	XR25U250	2500	1764	3179	3546	1085	718	470.5	470.5	6/12	2000	2500	2000	2500				
	XR25U270	2700	1864	3379	3746	1185	818	470.5	470.5	6/12	2000	2500	2000	2500				
	XR25U300	3000	2014	3679	4046	1335	968	470.5	470.5	6/12	2000	2500	2000	2500				
	XR25U330	3300	2164	3979	4346	1485	1118	470.5	470.5	6/12	2000	2500	2000	2500				
	XR25U360	3600	2314	4279	4646	1635	1268	470.5	470.5	6/12	2000	2500	2000	2500				
	XR25U400	4000	2564	4679	5046	1885	1518	470.5	470.5	6/12	2000	2500	2000	2500				
	XR25N400	4000	1964	4676	5046	1285	918	477.5	477.5	6/6	1950	2500	1950	2500				
	XR25N430	4300	2064	4976	5346	1385	1018	477.5	477.5	6/6	1900	2400	1950	2450				
Wide view full free triplex mast	XR25N450	4500	2114	5176	5546	1435	1068	477.5	477.5	6/6	1850	2300	1850	2400				
	XR25N470	4700	2214	5376	5746	1535	1168	477.5	477.5	6/6	1800	2200	1850	2300				
	XR25N480	4800	2264	5476	5846	1585	1218	477.5	477.5	6/6	1750	2100	1800	2300				
	XR25N500	5000	2364	5676	6046	1685	1318	477.5	477.5	6/6	1700	1900	1800	2250				
	XR25N550	5500	2564	6176	6546	1885	1518	477.5	477.5	3/6	1450	1600	1700	1900				
	XR25N600	6000	2814	6676	7046	2135	1768	477.5	477.5	3/6	1000	1050	1500	1750				
	XR25N650	6500	3014	7176	7546	2335	1968	477.5	477.5	3/6	/	/	1200	1450				
	XR25N700	7000	3264	7764	8046	2500	2218	477.5	477.5	3/6	/	/	1000	1150				

With sideshifter minus 150Kg,with integral sideshifter minus 100kg.

3.0/3.5/3.8t X series mast:(Pneumatic)

Type	Model	Max. fork height	Overall height						Free lift				Tilt range		Capacity					
			Lowered	Extended			Without backrest		With backrest		Front Overhang		F/R	Load capacity at 500mm						
				Without backrest		With backrest	Without backrest		With backrest		Single tire			Dual tire						
				3t	3.5t/3.8t	mm	mm	mm	mm	mm	mm	mm		mm	mm	mm	mm	mm	mm	mm
mm	mm	mm	mm	mm	mm	mm	mm	mm	mm	mm	mm	mm	mm	mm	mm	mm	mm			
Wide view mast	XR30/35M250	2500	1804	3209	3284	3645	165	170	165	170	475	480	6/12	3000	3500	3800	3000	3500	3800	
	XR30/35M270	2700	1904	3409	3484	3845	165	170	165	170	475	480	6/12	3000	3500	3800	3000	3500	3800	
	XR30/35M300	3000	2054	3709	3784	4140	165	170	165	170	475	480	6/12	3000	3500	3800	3000	3500	3800	
	XR30/35M330	3300	2204	4009	4084	4445	165	170	165	170	475	480	6/12	3000	3500	3800	3000	3500	3800	
	XR30/35M360	3600	2404	4309	4384	4745	165	170	165	170	475	480	6/12	3000	3500	3800	3000	3500	3800	
	XR30/35M400	4000	2654	4709	4784	5145	165	170	165	170	475	480	6/12	3000	3500	3800	3000	3500	3800	
	XR30/35M430	4300	2804	5009	5084	5445	165	170	165	170	475	480	6/6	3000	3500	3800	3000	3500	3800	
	XR30/35M450	4500	2904	5209	5284	5645	165	170	165	170	475	480	6/6	3000	3200	3550	3000	3300	3700	
	XR30/35M480	4800	3054	5509	5584	5945	165	170	165	170	475	480	6/6	2850	3000	3100	2900	3150	3300	
	XR30/35M500	5000	3154	5709	5784	6145	165	170	165	170	475	480	6/6	2650	2850	3000	2700	2900	3200	
Wide view full free duplex mast	XR30/35M550	5500	3404	6209	6284	6645	165	170	165	170	475	480	3/6	2250	2300	2500	2400	2700		